

CD0022

REV. ECN NO.		REVISIONS DESCRIPTION	BY	DATE
A	43802	RELEASE FOR PRODUCTION	JLA	31MAY2023
B	44115	FORMAT AND DIMENSION CHANGES	JLA	15JUN2023

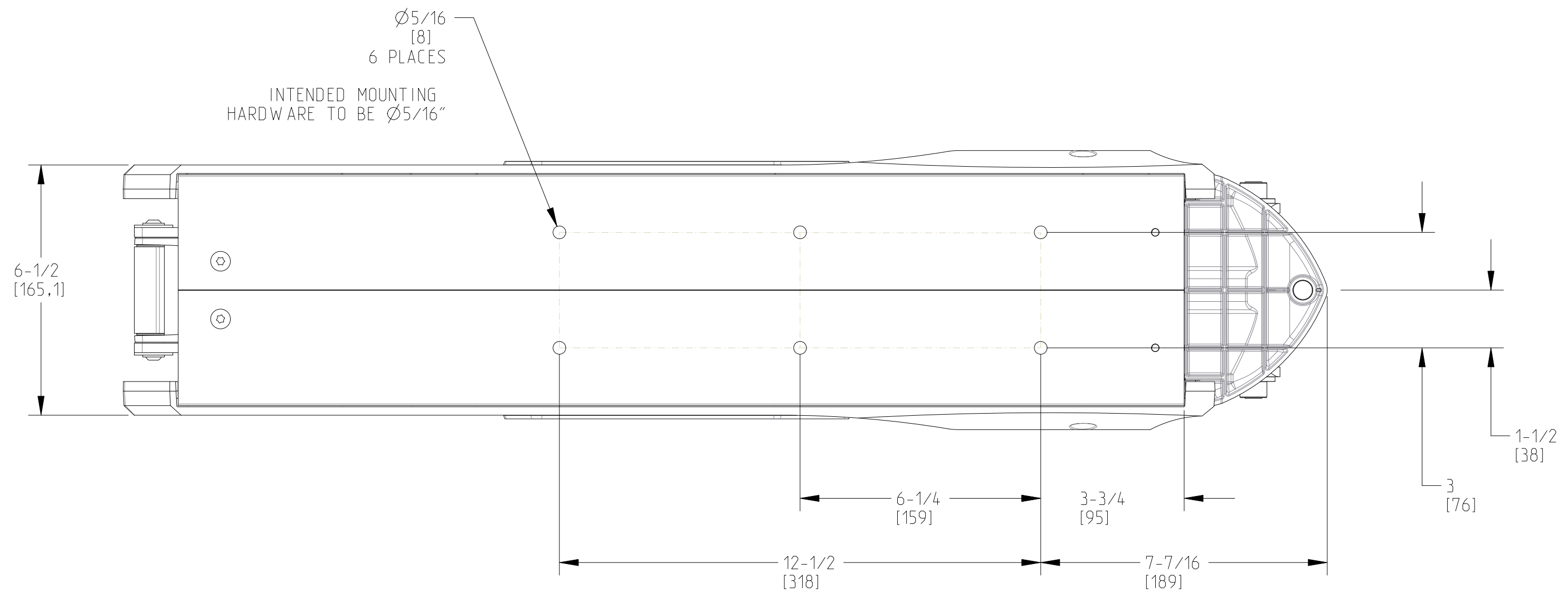
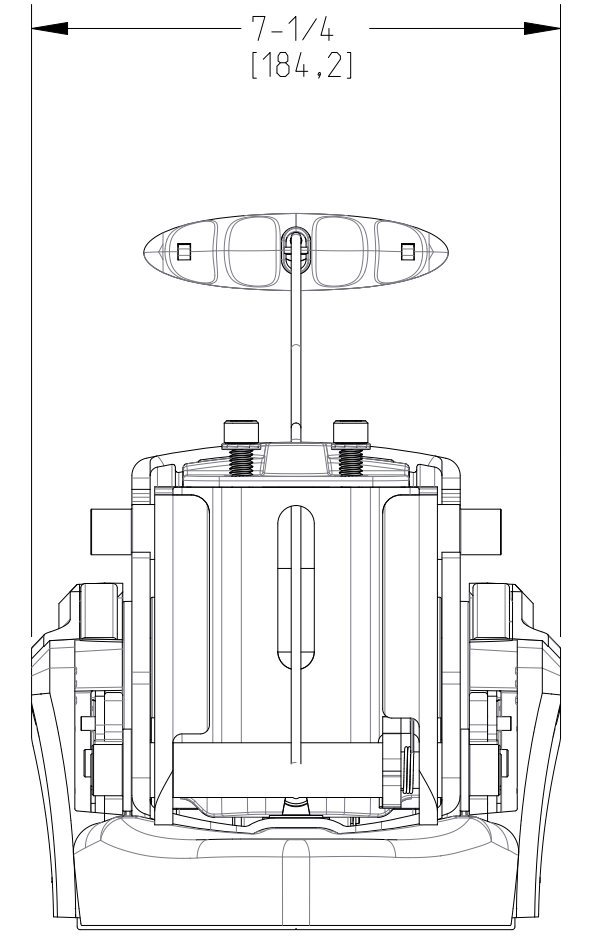
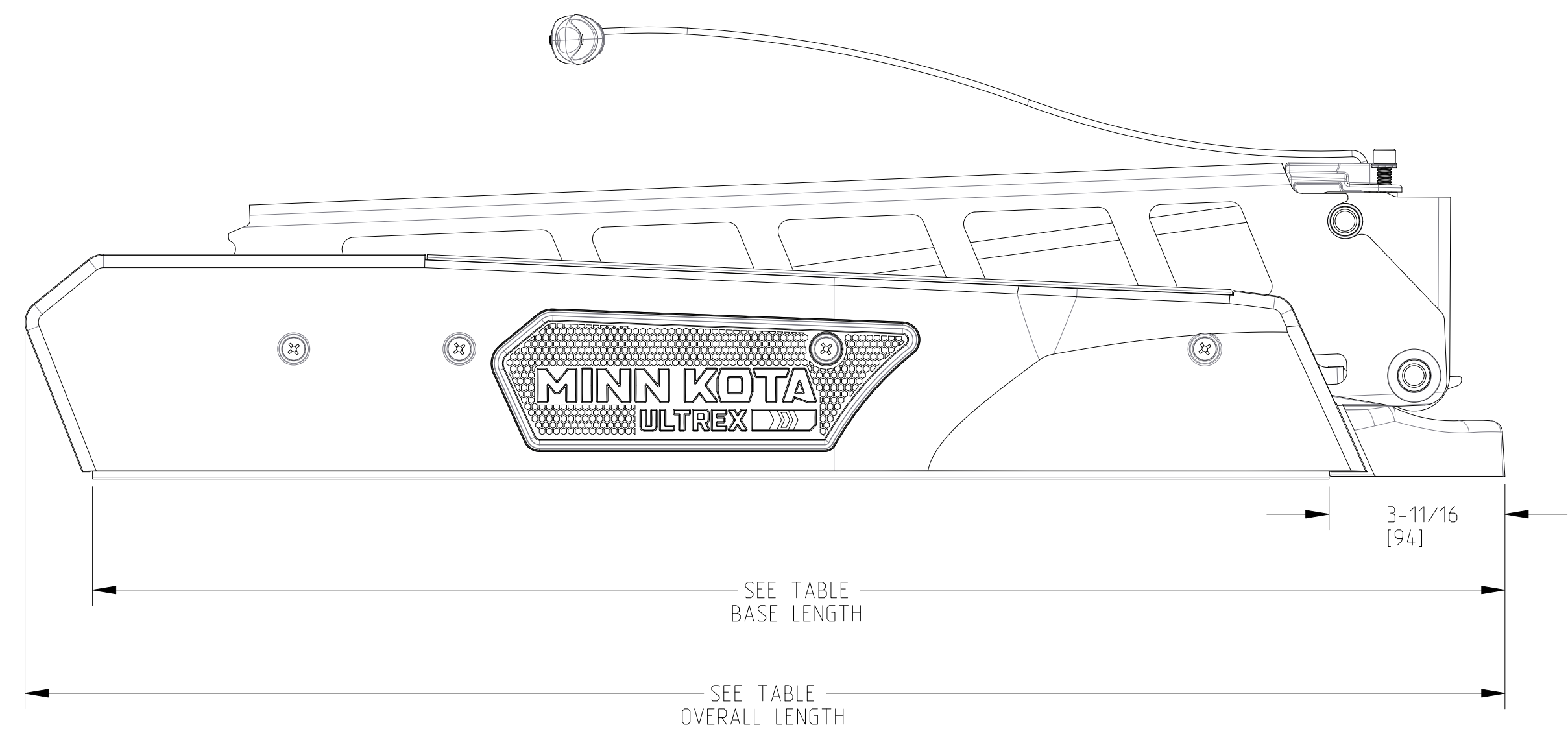
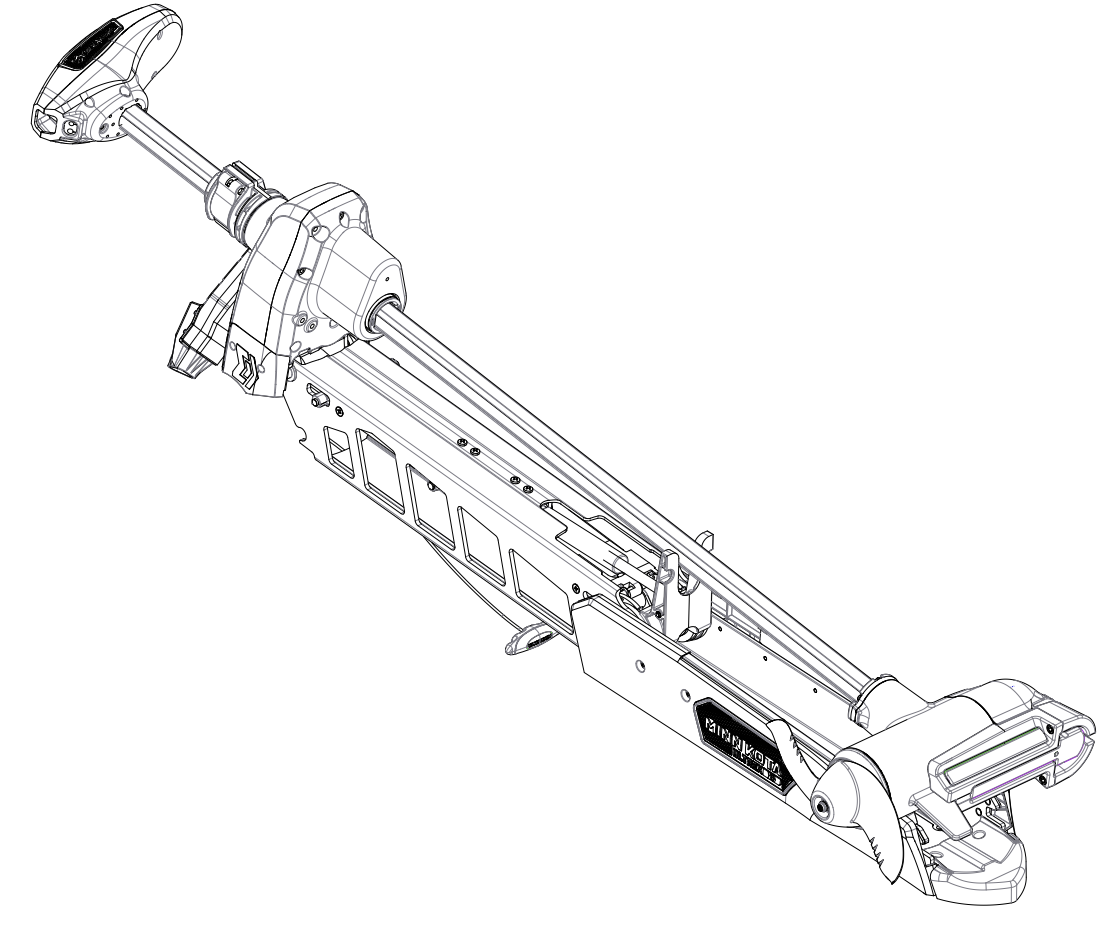

MODEL	BASE LENGTH	OVERALL LENGTH
45"	26-5/16 [668]	27-13/16 [706]
52"	29-13/16 [757]	31-5/16 [795]
62"	29-13/16 [757]	31-5/16 [795]

CAUTION: ALWAYS WEAR SAFETY GLASSES AND GLOVES. DISCONNECT ALL POWER BEFORE BEGINNING ANY WORK OR MAINTENANCE. JOHNSON OUTDOORS, INC. IS NOT RESPONSIBLE FOR ANY DAMAGE DUE TO IMPROPER RIGGING OR INSTALLATION. IF YOU DO NOT HAVE THE SKILLS, EXPERIENCE AND TOOLS TO PERFORM THE FOLLOWING MAINTENANCE AND REPAIRS, WE RECOMMEND YOU SEEK THE HELP OF AN AUTHORIZED SERVICE CENTER. OR CONTACT OUR TECHNICAL SERVICE DEPARTMENT BY DIALING 800-227-6433.

**CUSTOMER DRAWING**

JOHNSON OUTDOORS  
MARINE ELECTRONICS, INC.

DRAWING NAME: ULTREX 90/115

DRAWING NO: CD0022

SHEET 1 OF 2

U/A: IN. (MM)

REV: B

D SIZE

CD0022

REV. ECN NO.		REVISIONS DESCRIPTION	BY	DATE
		SEE SHEET 1 FOR DETAILS		

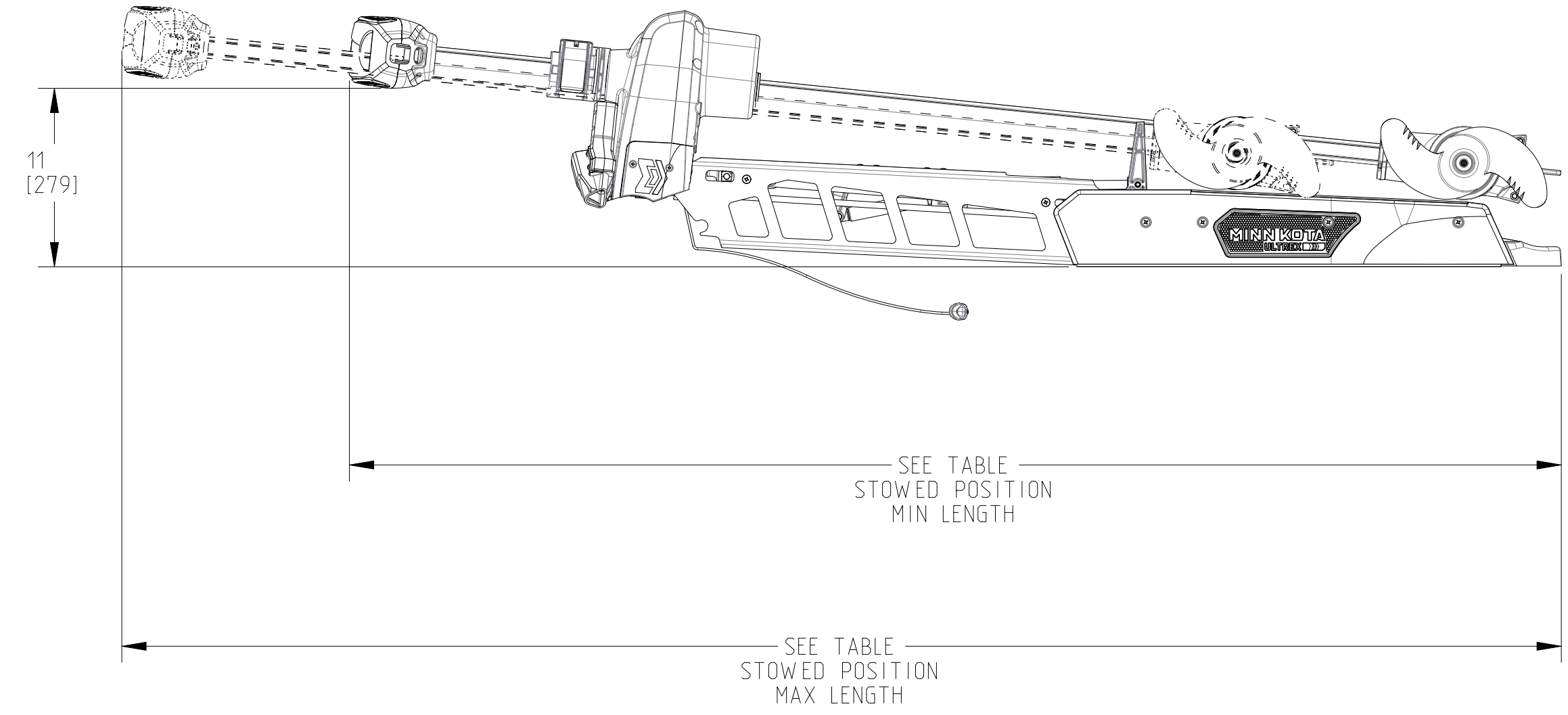
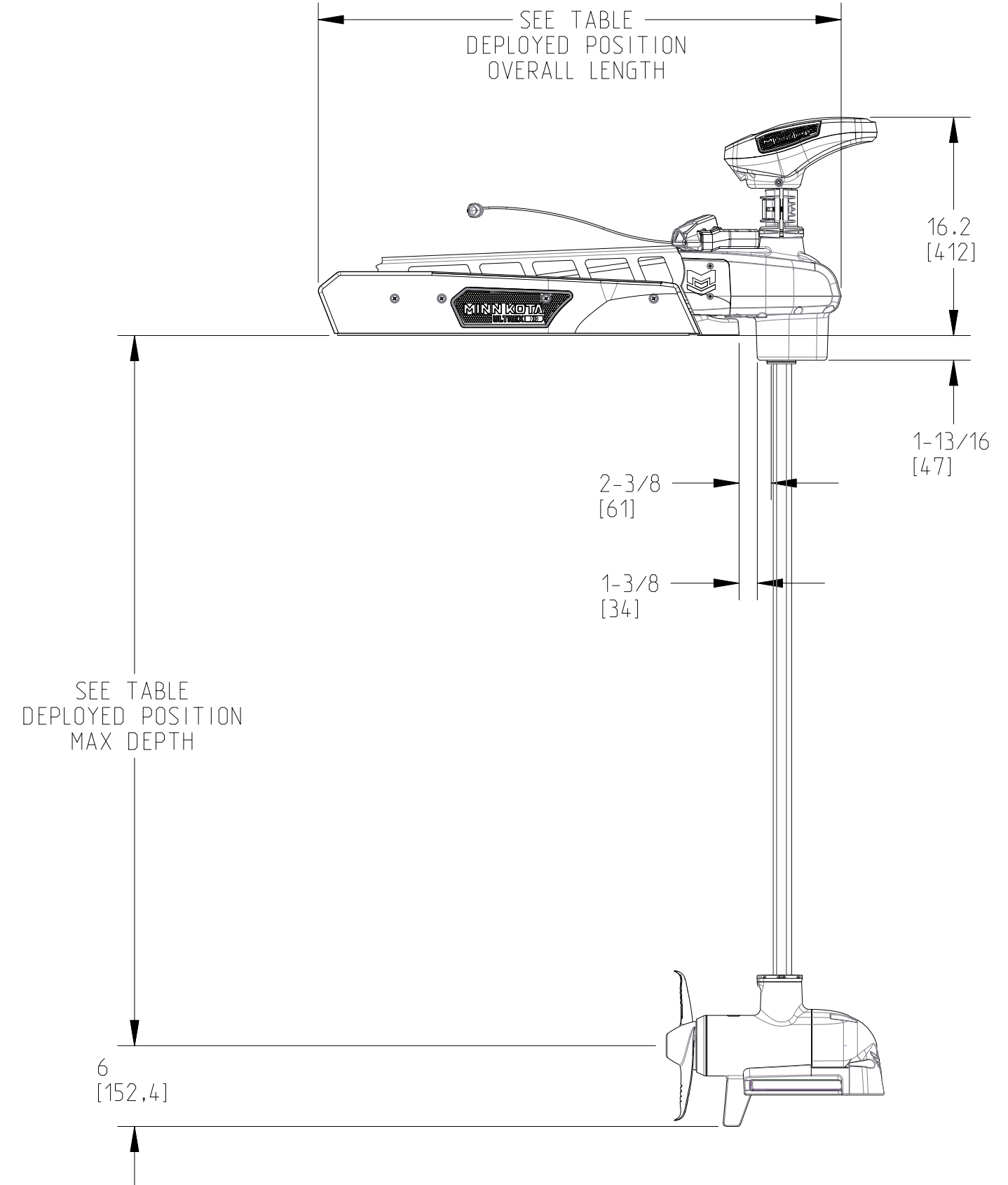
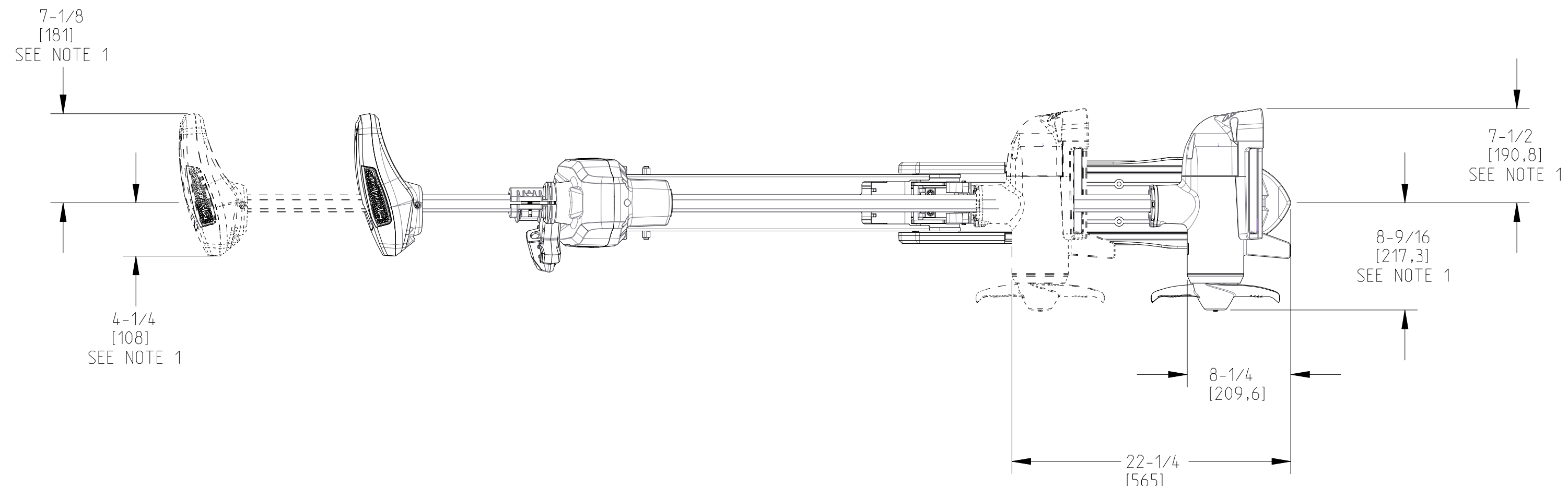
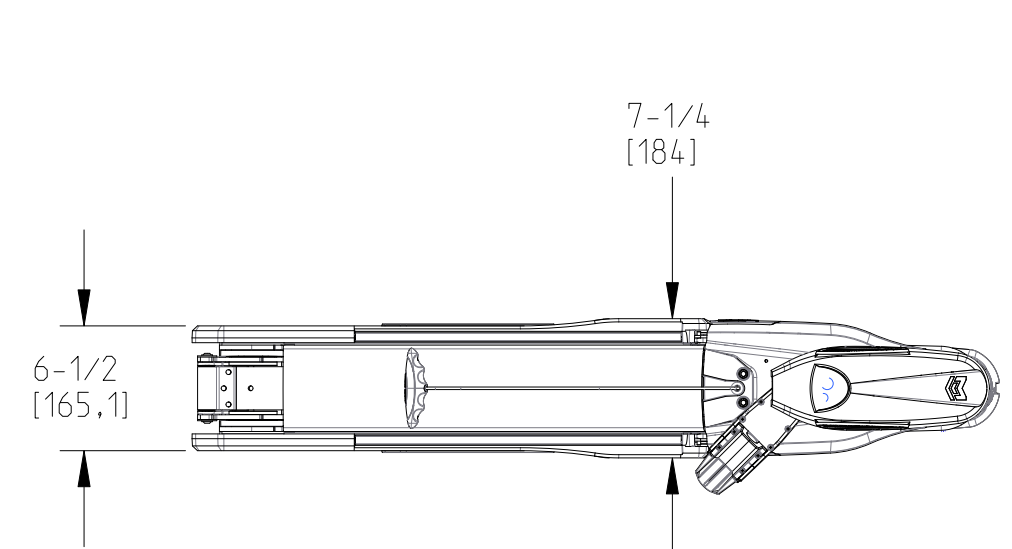

DEPLOYED POSITION		
MODEL	OVERALL LENGTH	MAX DEPTH
45"	35-5/16 [897]	38-13/16 [985]
52"	38-13/16 [985]	45-5/8 [1158]
62"	38-13/16 [985]	52-11/16 [1339]

STOWED POSITION		
MODEL	MIN LENGTH	MAX LENGTH
45"	59-5/8 [1514]	73-5/8 [1869]
52"	67-7/16 [1712]	81-7/16 [2068]
60"	74-11/16 [1897]	88-1/2 [2248]

NOTES:  
1. MOTOR IS ABLE TO BE ORIENTED WITH PROP ON EITHER SIDE OF MOUNT

CAUTION: ALWAYS WEAR SAFETY GLASSES AND GLOVES. DISCONNECT ALL POWER BEFORE BEGINNING ANY WORK OR MAINTENANCE. JOHNSON OUTDOORS INC. IS NOT RESPONSIBLE FOR ANY DAMAGE DUE TO IMPROPER RIGGING OR INSTALLATION. IF YOU DO NOT HAVE THE SKILLS, EXPERIENCE AND TOOLS TO PERFORM THE FOLLOWING MAINTENANCE AND REPAIRS, WE RECOMMEND YOU SEEK THE HELP OF AN AUTHORIZED SERVICE CENTER. OR CONTACT OUR TECHNICAL SERVICE DEPARTMENT BY DIALING 800-227-6433.

**CUSTOMER DRAWING**  
 JOHNSON OUTDOORS  
 MARINE ELECTRONICS, INC.  
 DRAWING NAME: ULTREX 90/115  
 DRAWING NO: CD0022  
 SHEET OF: 1  
 U/A: IN. (MM)  
 REV: B  
 D SIZE: B